



DEVO1 /MILO360

AISI 316/L STAINLESS STEEL

Deviatore apri/chiedi a parete 2 vie

Wall mounted 2 way shut-off diverter



Alta portata (≥ 25 l/min)
High water flow (≥ 25 l/min / ≥ 6.6 gpm)

Prodotto che necessita di parte incasso
Product that needs built-in part

Staffa ausiliaria per cartongesso / fibrogesso
Auxiliary bracket for plasterboard / fiber-board structures

MANUTENZIONE / MAINTENANCE

NON UTILIZZARE DO NOT USE		acido clorico e muriatico chloric and muriatic acid
		acido fluoridrico hydrofluoric acid
		ipoclorito di sodio chlorine bleach
UTILIZZARE TO USE		sapone a PH neutro neutral PH soap

Questi disegni sono proprietà di CEADESIGN SRL s.u. pertanto non potranno essere utilizzati e/o comunicati a terzi, anche in forma parziale, senza preventiva autorizzazione. CEADESIGN SRL s.u. si riserva il diritto di apportare modifiche ai disegni al fine di migliorare il prodotto.

CEADESIGN SRL s.u. has the property rights on these drawings, therefore they cannot be used and/or transferred to third party, even in partial form, without any prior authorization. Furthermore CEADESIGN SRL s.u. reserves the right to apply any change to these drawings in order to upgrade the product.

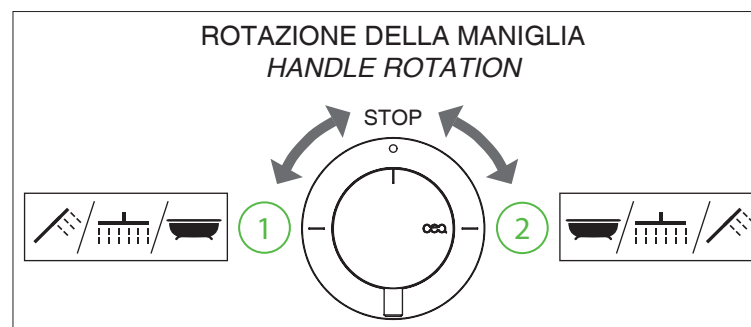
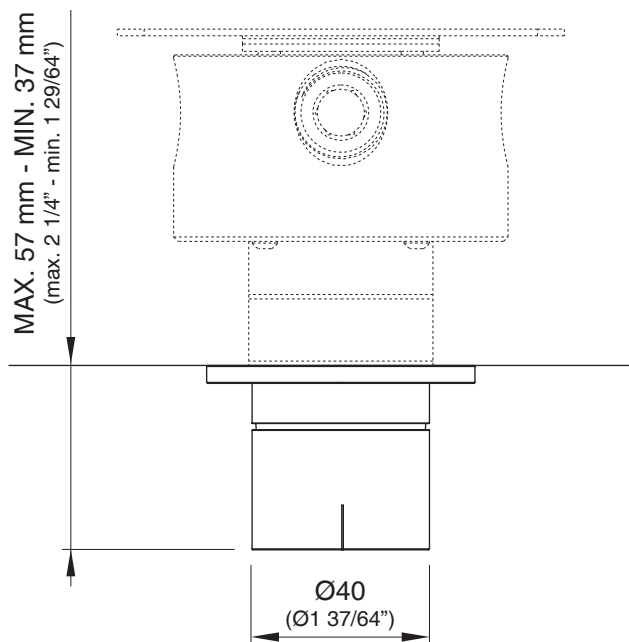
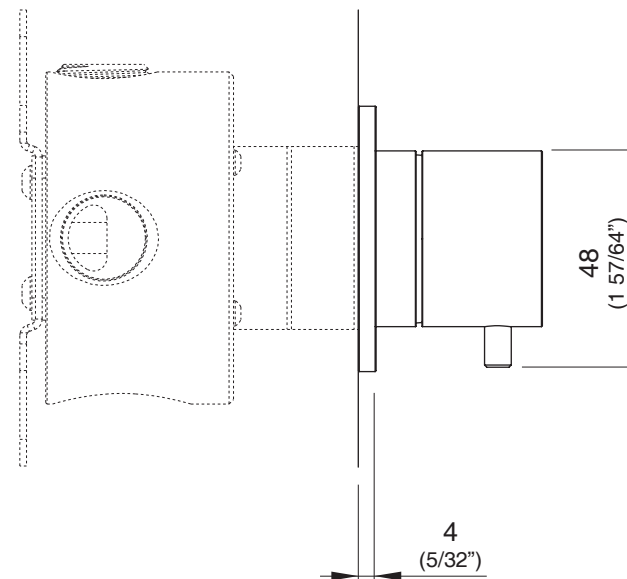
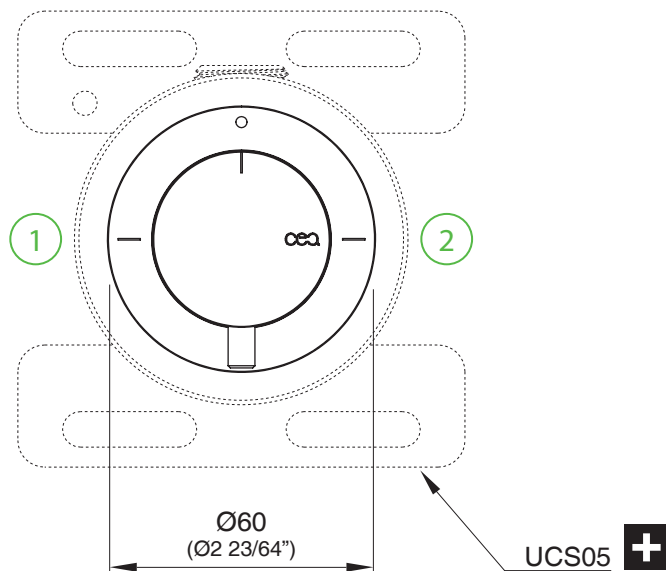

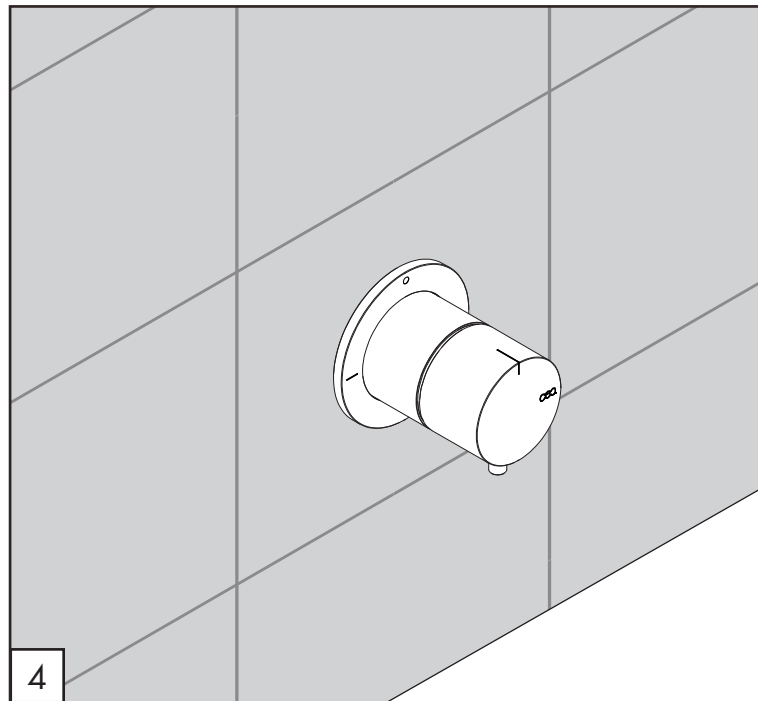
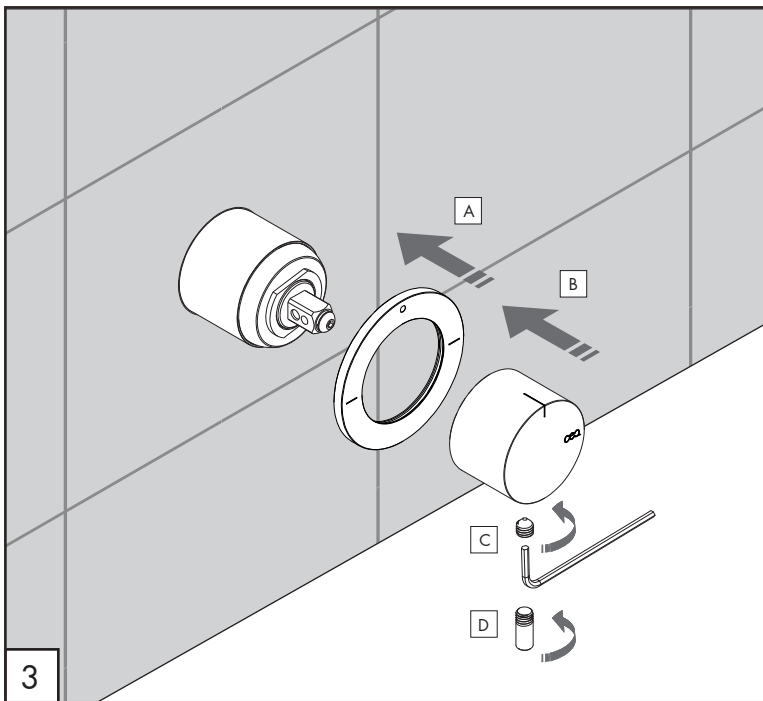
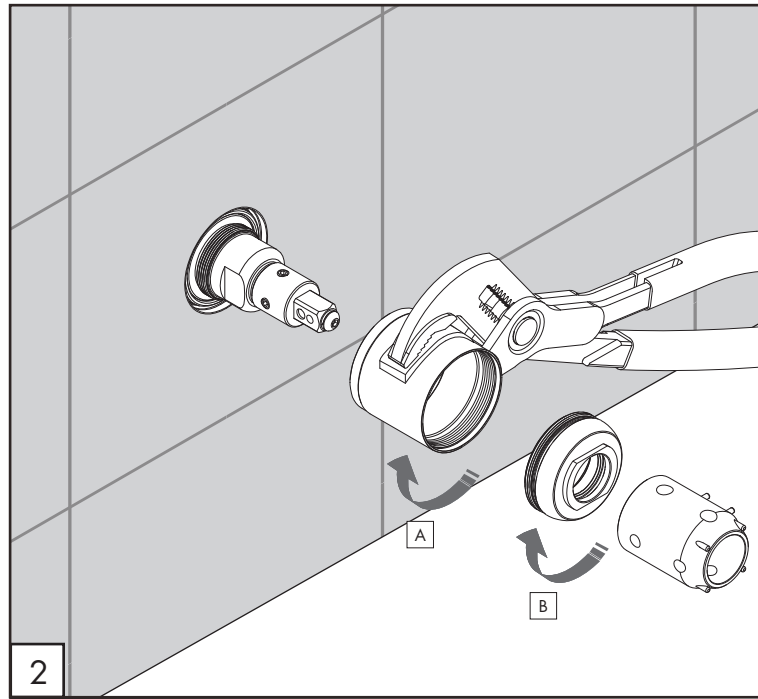
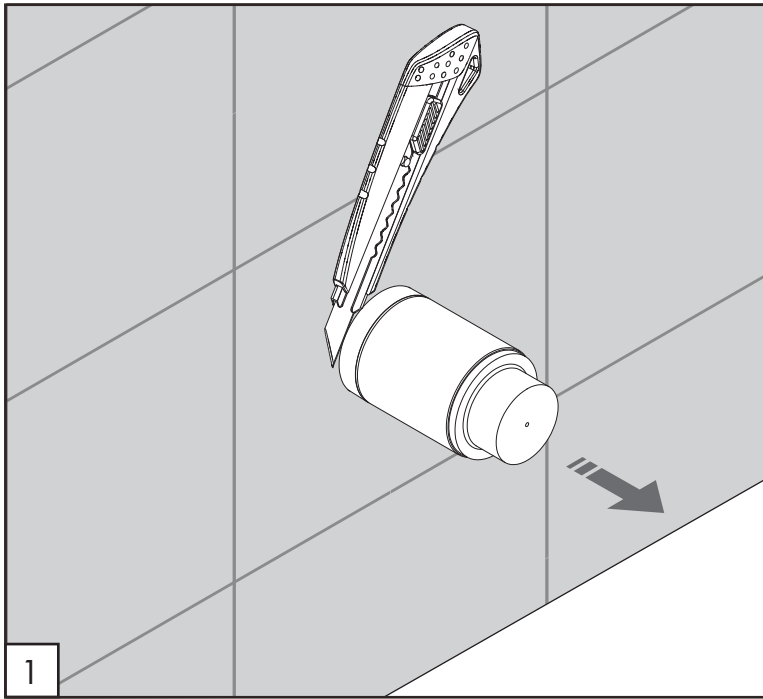

DEVO 1 _REV10



AVVERTENZE TECNICHE

Risciacquare bene le tubazioni prima del montaggio ed evitare sbalzi di pressione fra i raccordi d'acqua fredda e d'acqua calda. In caso di pressioni statiche superiori a 5 bar si raccomanda l'installazione di un riduttore di pressione per evitare danni alla cartuccia.

TECHNICAL WARNINGS

The pipes have to be rinsed thoroughly before installation. Avoid pressure differences between hot and cold water supply. Use of a pressure reducer when static pressure is higher than 5 bar to avoid damage of the cartridge.

TECHNISCHE WARNUNG

Spülen Sie die Leitungen vor dem Einbau und verhindern Sie Wasserdruckwechsel zwischen kalt und warm Wasserverbindungen. Wenn Wasserdruck größer als 5 bar ist, bitte reduzieren Sie den Systemdruck, um Beschädigung der Kartusche zu verhindern.

ADVERTENCIA TÉCNICA

Los tubos tienen que ser enjuagados a fondo antes de la instalación. Evitar grandes diferencias de presión entre las conexiones de agua caliente y fría. En caso de presión estática mayor de 5 bar, se recomienda el uso de un adaptador de presión para evitar daños en el cartucho.

ADVERTISSEMENTS TECHNIQUES

Rincer les tuyaux avant l'installation. Eviter des grandes différences de pression entre l'eau froide et chaude. En cas de pressions statique de plus de 5 bar, nous vous recommandons d'installer un réducteur de pression pour éviter des dommages à la cartouche.

PORTATE / FLOW RATE

BAR	uscita 1 / outlet 1		uscita 2 / outlet 2	
	l/min	gpm	l/min	gpm
1	15,6	4.1	17,3	4.6
2	21,7	5.7	24,2	6.4
3*	26,2	6.9	29,0	7.7
4	29,6	7.8	32,3	8.5
5	32,2	8.5	35,5	9.4

* Pressione consigliata
Recommended pressure

max. 60 °C
max. 140 °F

CEQ

RICAMBI / SPARE PARTS

RICB004	Carter / <i>Carter</i>
RICH034	Ghiera / <i>Sleeve</i>
RICM019	Maniglia / <i>Handle</i>
RICR049	Rosetta / <i>Rosette</i>
RICS246	Perno maniglia L.8 mm <i>L.8 mm lever for handle</i>

ROSETTA SU RICHIESTA / ROSETTE ON DEMAND

RICR120	Rosetta Ø esterno 70 mm <i>Rosette external Ø 70 mm</i>
---------	--

Conservare gli strumenti inclusi nel prodotto e utilizzati per l'installazione perchè riutilizzabili per i ricambi.
Please, keep the tools included in the item pack and employed for its installation, to re-used them for the spare parts.

Die Werkzeuge, die Sie für die Installation des Produktes benutzt haben, bitte aufbewahren, da sie auch für die Installation der Ersatzteile benutzt werden können.

No tirar las herramientas incluidas en el producto y usadas durante la instalación puesto que se pueden reutilizar para los recambios.

Veillez conserver les outils inclus dans la boîte du produit et employés pour son installation, parce que réutilisables pour les pièces de rechange.

LEGENDA / LEGEND

ICONE / ICONS

Utensile incluso nel ricambio
Tool included in spare part

FINITURE / FINISHES

*S finitura satinata / *satin finish*
L finitura lucidata / *polished finish*

FINITURE SPECIALI / SPECIAL FINISHES

KD black diamond
Z bronzo / *bronze*
P rame / *copper*
X light gold

