

AQC13 _REV11

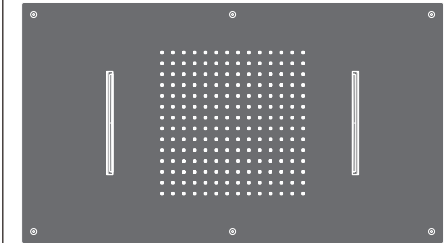

AQC13/FREE IDEAS

AISI 316/L STAINLESS STEEL

Soffione ad incasso con getto a pioggia, getto a cascata e ugelli in silicone

Built-in shower head with rain, waterfall jets and silicone nozzles

CEA DESIGN STUDIO

MANUTENZIONE / MAINTENANCE

NON UTILIZZARE DO NOT USE		acido clorico e muriatico <i>chloric and muriatic acid</i>
		acido fluoridrico <i>hydrofluoric acid</i>
		ipoclorito di sodio <i>chlorine bleach</i>
UTILIZZARE TO USE		sapone a PH neutro <i>neutral PH soap</i>

Questi disegni sono proprietà di CEADDESIGN SRL s.u. pertanto non potranno essere utilizzati e/o comunicati a terzi, anche in forma parziale, senza preventiva autorizzazione. CEADDESIGN SRL s.u. si riserva il diritto di apportare modifiche ai disegni al fine di migliorare il prodotto.

CEADDESIGN SRL s.u. has the property rights on these drawings, therefore they cannot be used and/or transferred to third party, even in partial form, without any prior authorization. Furthermore CEADDESIGN SRL s.u. reserves the right to apply any change to these drawings in order to upgrade the product.

CEA

ceadesign.it

GETTO A CASCATA / WATERFALL JET

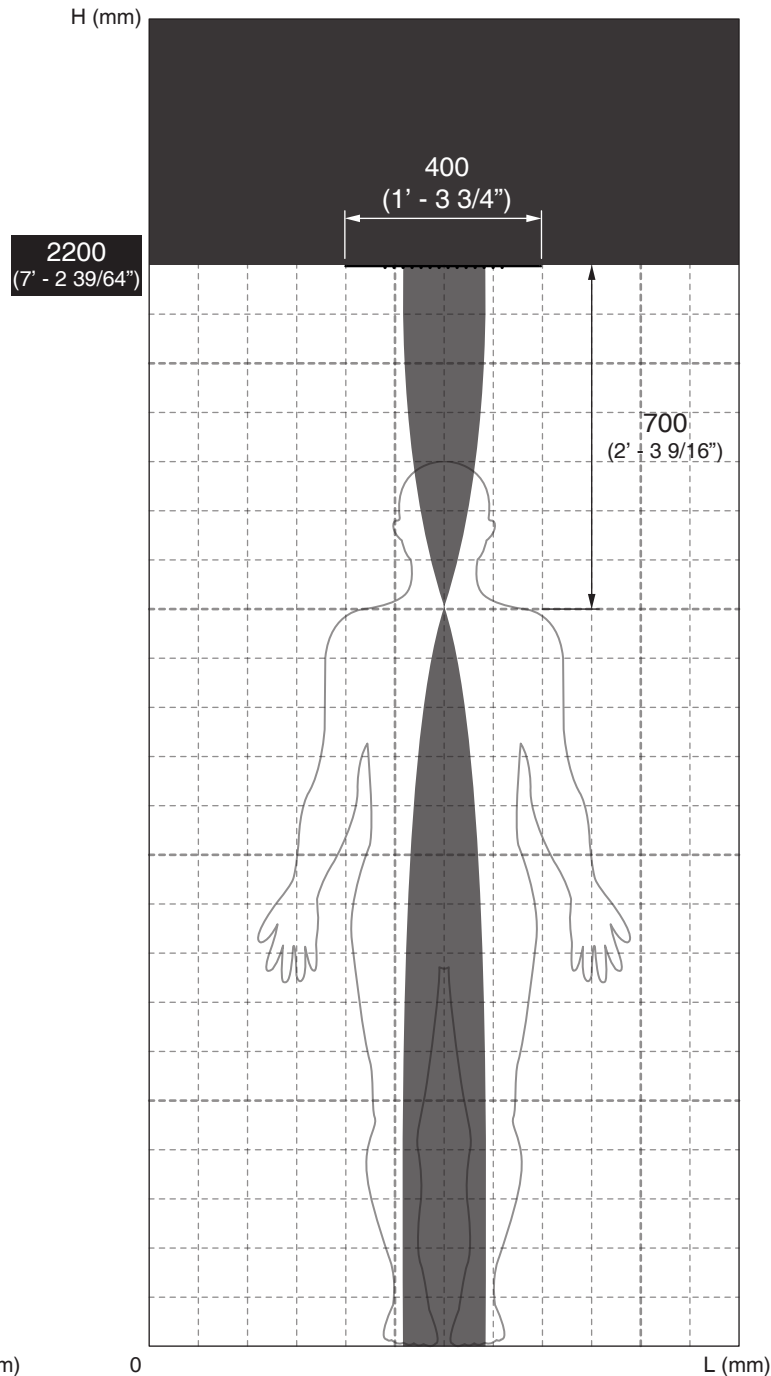
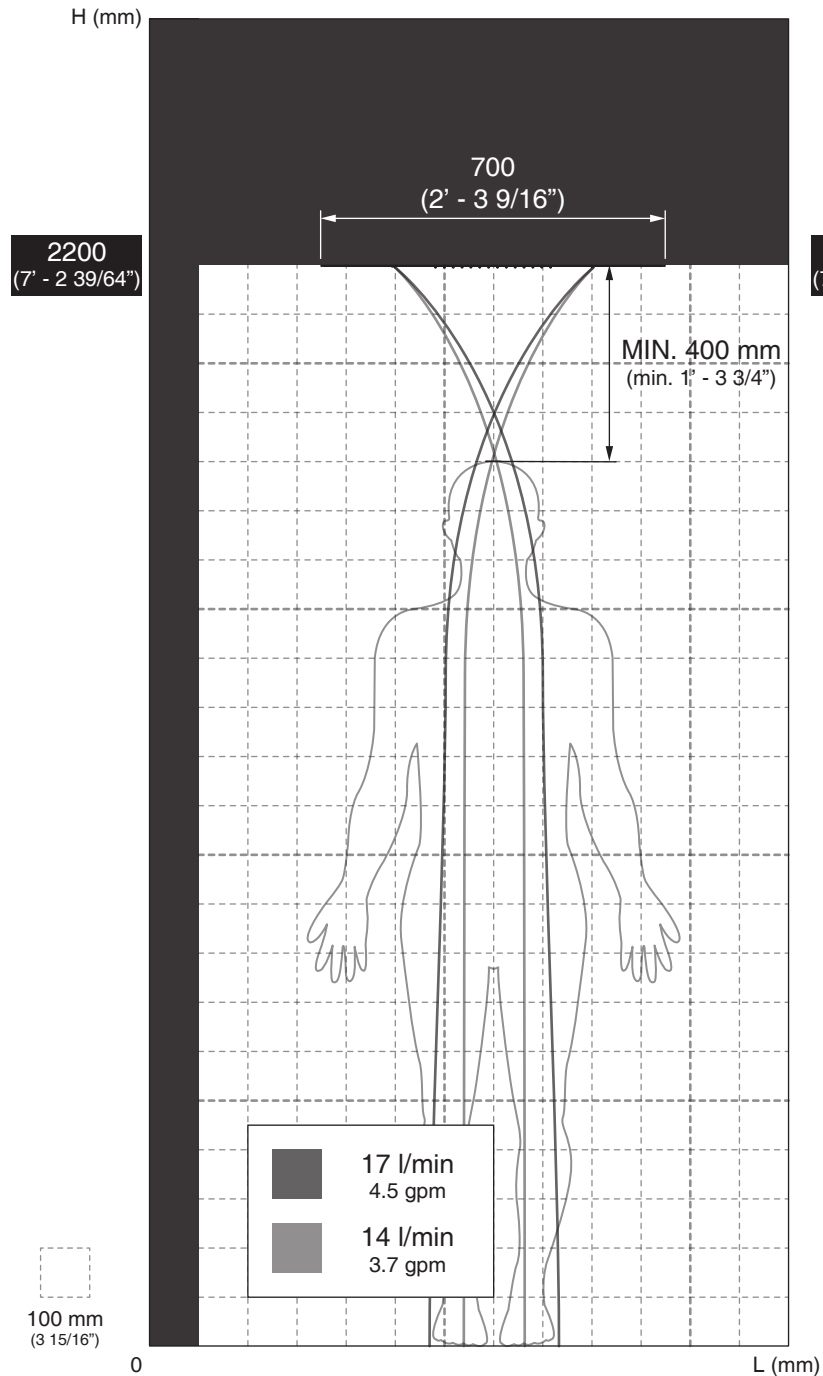

AQC13

_REV1.1

AVVERTENZE DI INSTALLAZIONE

L'altezza ottimale d'installazione del prodotto si determina in base all'altezza dell'utente.
La rappresentazione ha valore puramente indicativo.

INSTALLATION WARNINGS

Each individual product has to be installed and adjusted to suit the user's height.
The representation is purely indicative.

INSTALLATIONS WARNING

Die optimale Anbringungshöhe der einzelnen Produkte ist abhängig von der Körpergröße der Benutzer.
Die Zeichnung ist rein indikativ.

ADVERTENCIAS DE INSTALACIÓN

La altura de colocación ideal de cada producto se determina conforme a la altura de la persona.
La representación es indicativa.

AVERTISSEMENTS D'INSTALLATION

La hauteur optimale de l'emplacement du produit est à déterminer selon la taille de la personne.
La représentation est purement indicative.

PORTATA CONSIGLIATA / ECOMMENDED FLOW RATE

Getto a cascata / Waterfall jet
17 l/min / 4.5 gpm (pressione di 2,5 bar / pressure of 2,5 bar)

PORTATA MINIMA / MANIMUM FLOW RATE *

Getto a cascata / Waterfall jet
14 l/min / 3.7 gpm (pressione di 2 bar / pressure of 2 bar)

* Il flusso è determinato dalla portata del comando abbinato
The flow is determined by the range of the combined control

CEA

GETTO A PIOGGIA / RAIN JET

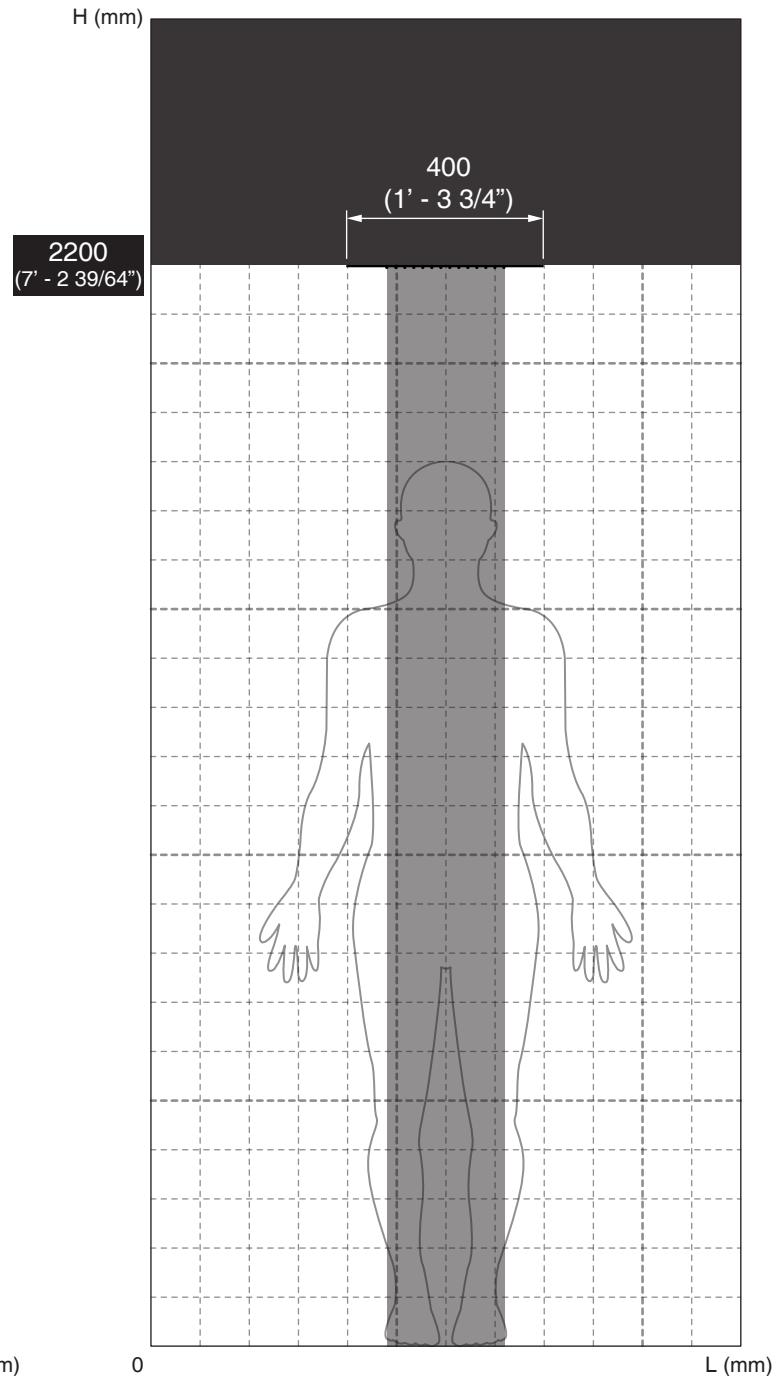
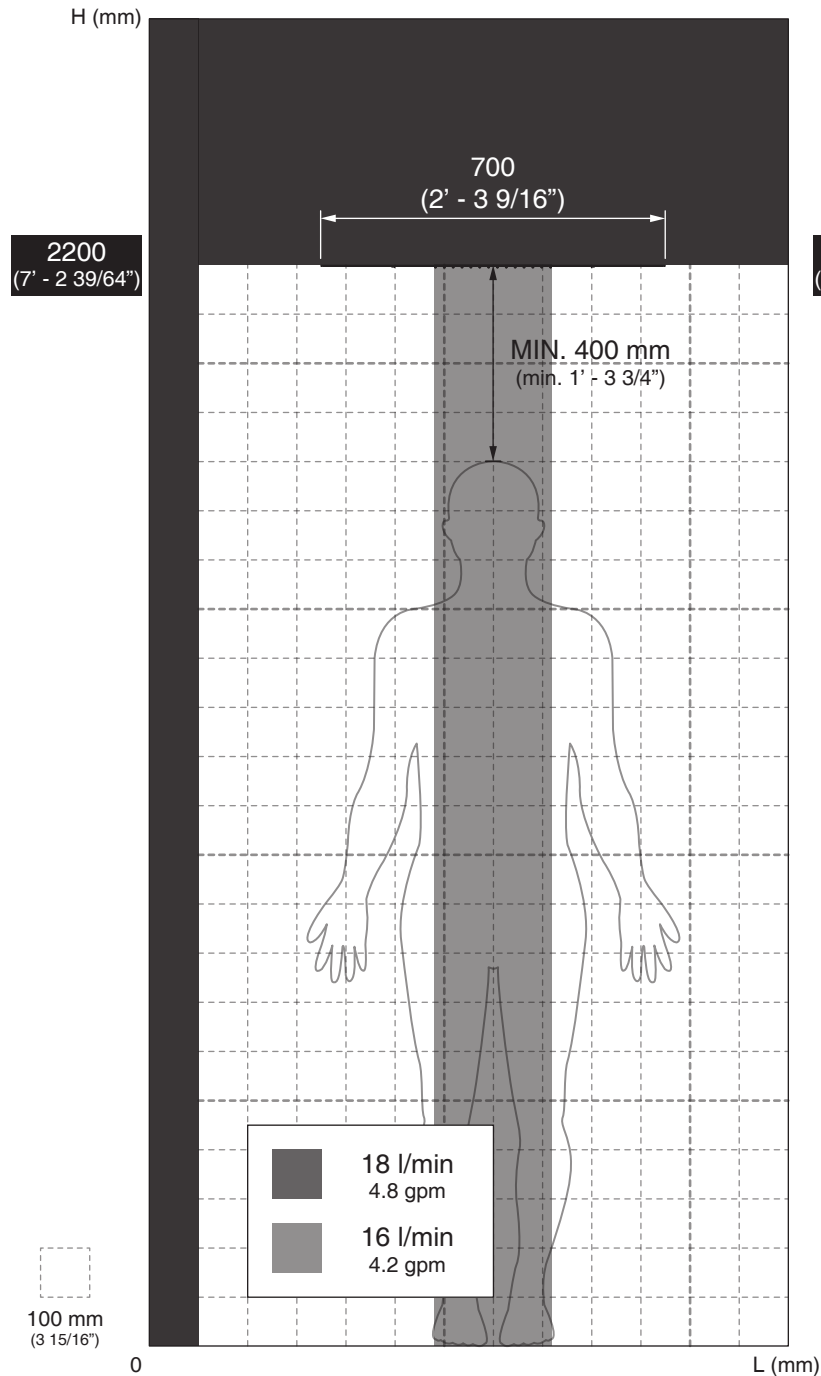

AQC13

_REV1.1

AVVERTENZE DI INSTALLAZIONE

L'altezza ottimale d'installazione del prodotto si determina in base all'altezza dell'utente.
La rappresentazione ha valore puramente indicativo.

INSTALLATION WARNINGS

Each individual product has to be installed and adjusted to suit the user's height.
The representation is purely indicative.

INSTALLATIONS WARNING

Die optimale Anbringungshöhe der einzelnen Produkte ist abhängig von der Körpergröße der Benutzer.
Die Zeichnung ist rein indikativ.

ADVERTENCIAS DE INSTALACIÓN

La altura de colocación ideal de cada producto se determina conforme a la altura de la persona.
La representación es indicativa.

AVERTISSEMENTS D'INSTALLATION

La hauteur optimale de l'emplacement du produit est à déterminer selon la taille de la personne.
La représentation est purement indicative.

PORTATA CONSIGLIATA / ECOMMENDED FLOW RATE

Getto a pioggia / Rain jet
18 l/min / 4.8 gpm (pressione di 2,5 bar / pressure of 2,5 bar)

PORTATA MINIMA / MANIMUM FLOW RATE *

Getto a pioggia / Rain jet
16 l/min / 4.2 gpm (pressione di 1,5 bar / pressure of 1,5 bar)

* Il flusso è determinato dalla portata del comando abbinato
The flow is determined by the range of the combined control

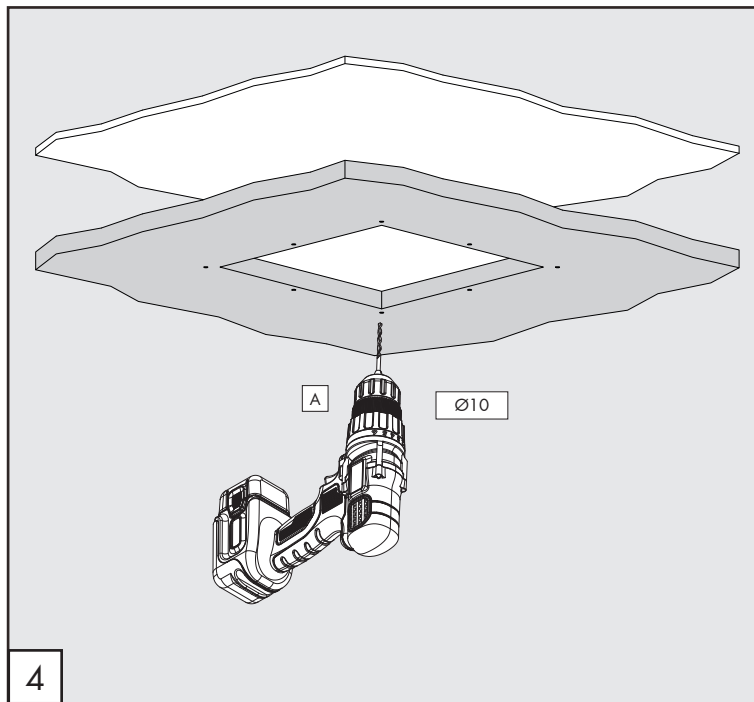
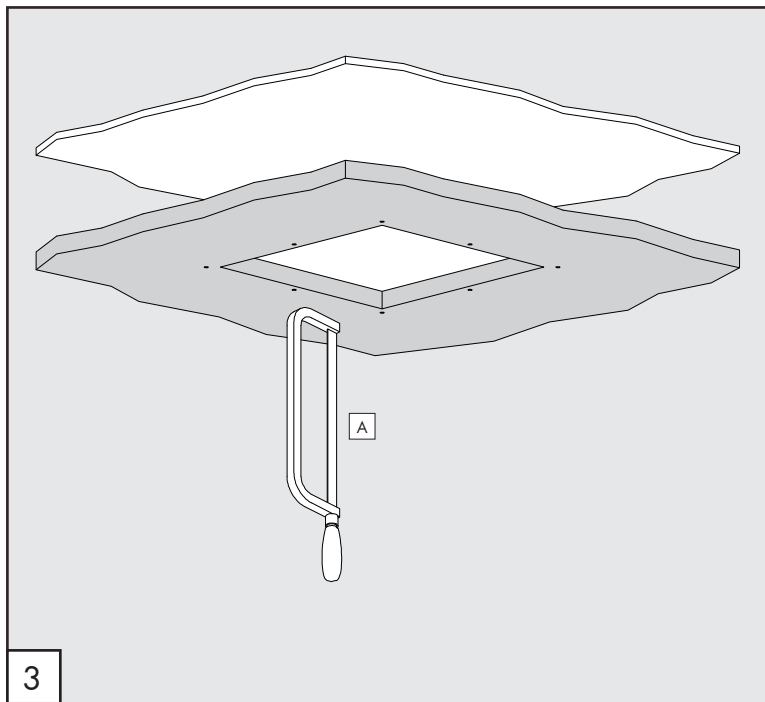
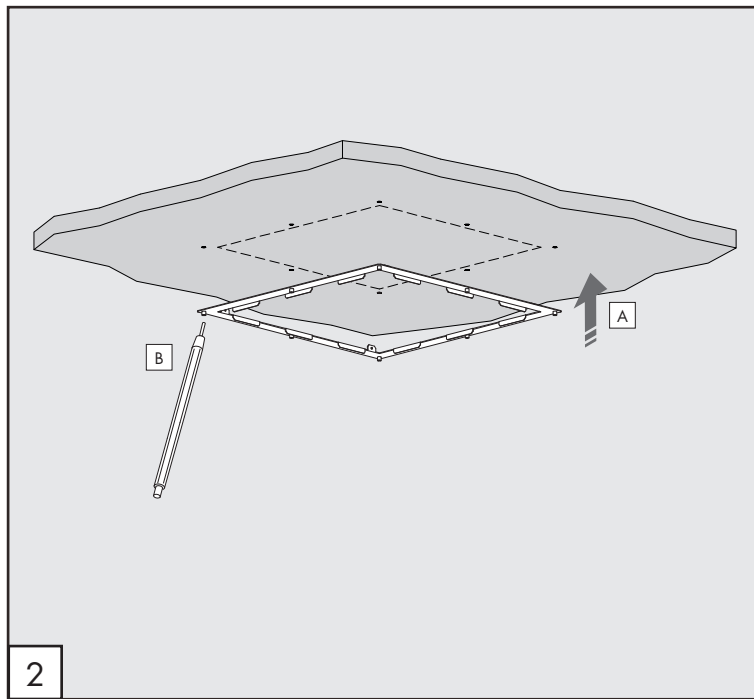
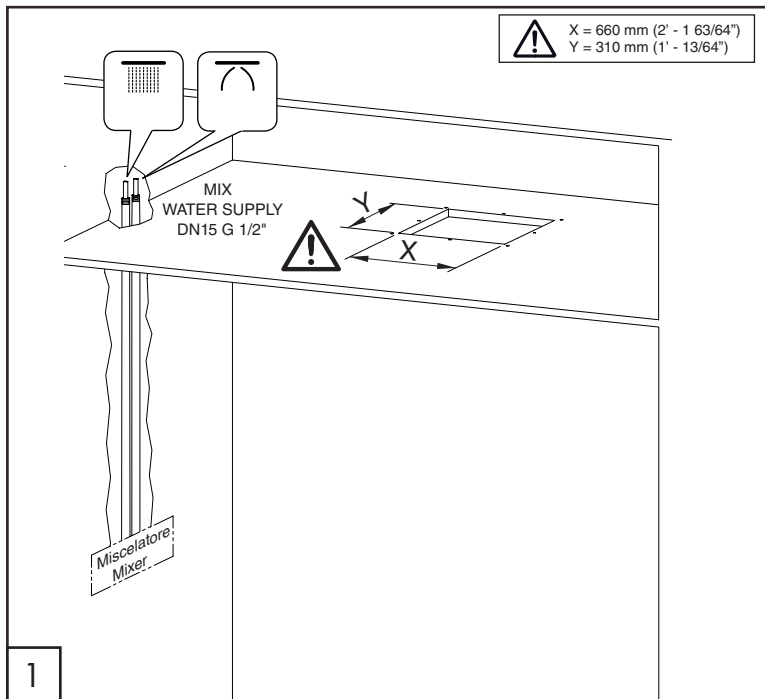

AQC13_REV1.1

AVVERTENZE TECNICHE

Risciacquare bene le tubazioni prima del montaggio.

TECHNICAL WARNINGS

The pipes have to be rinsed thoroughly before installation.

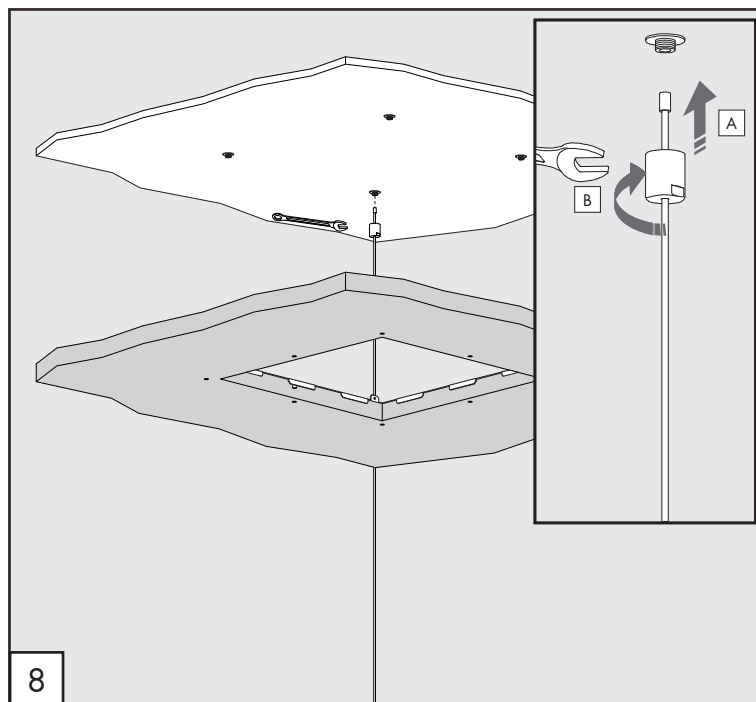
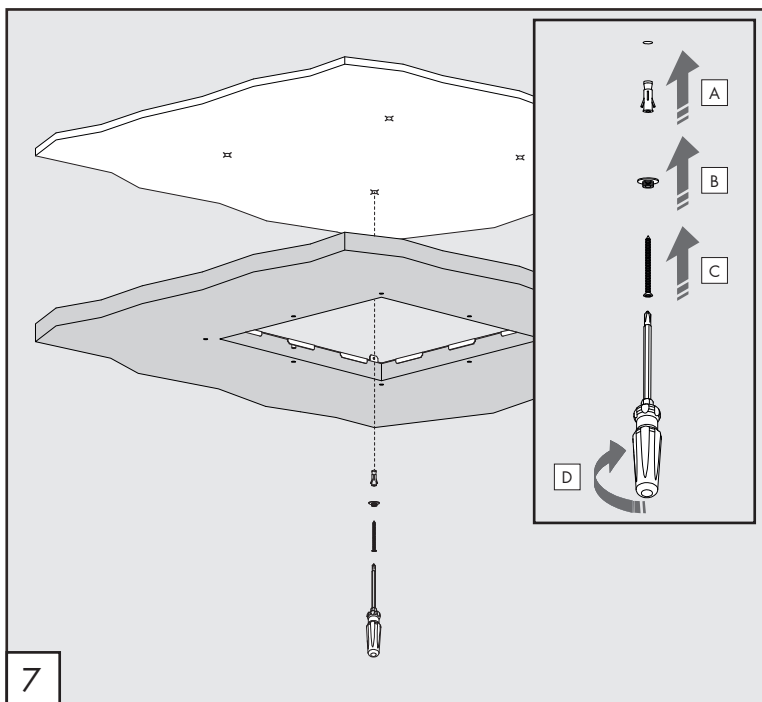
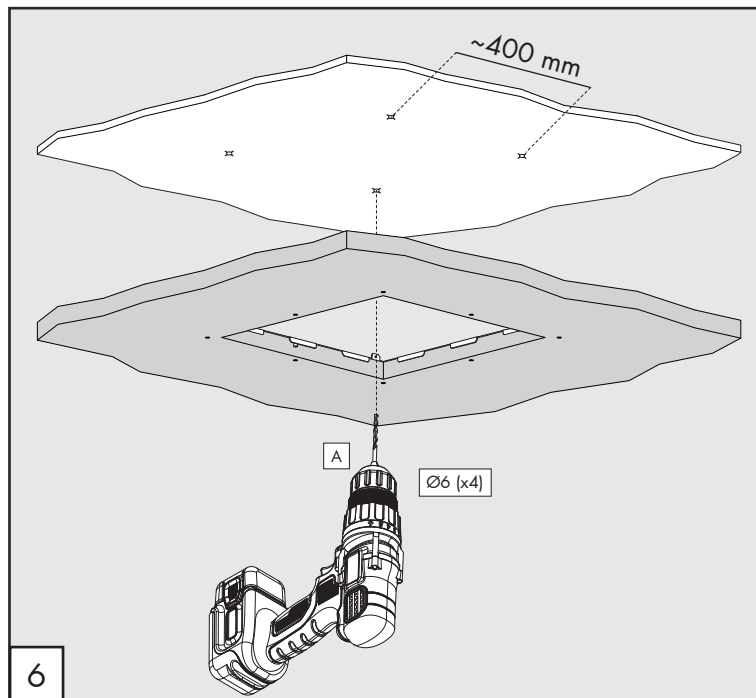
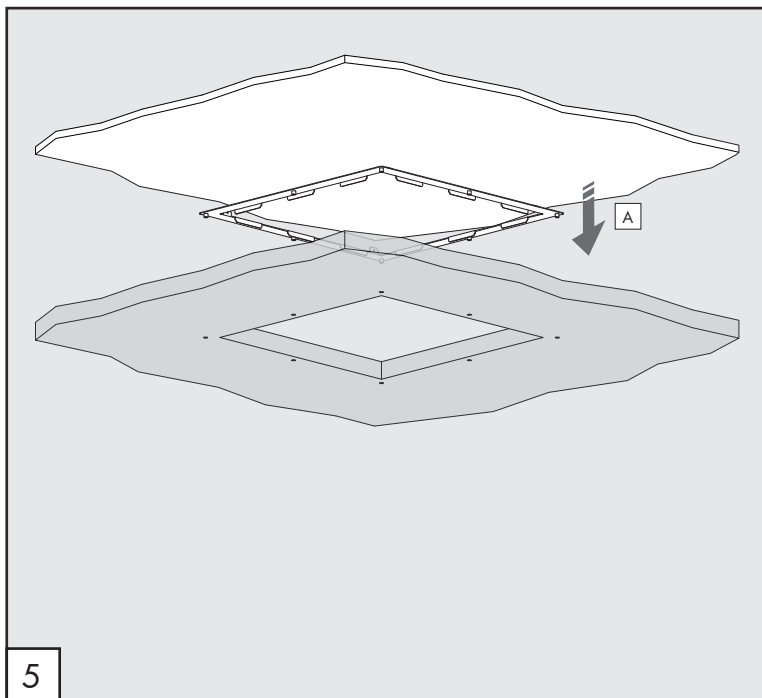

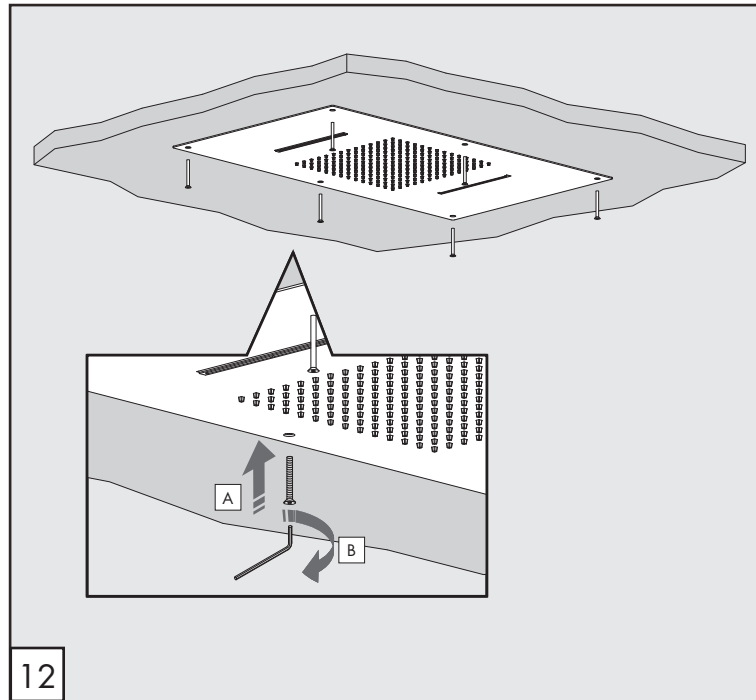
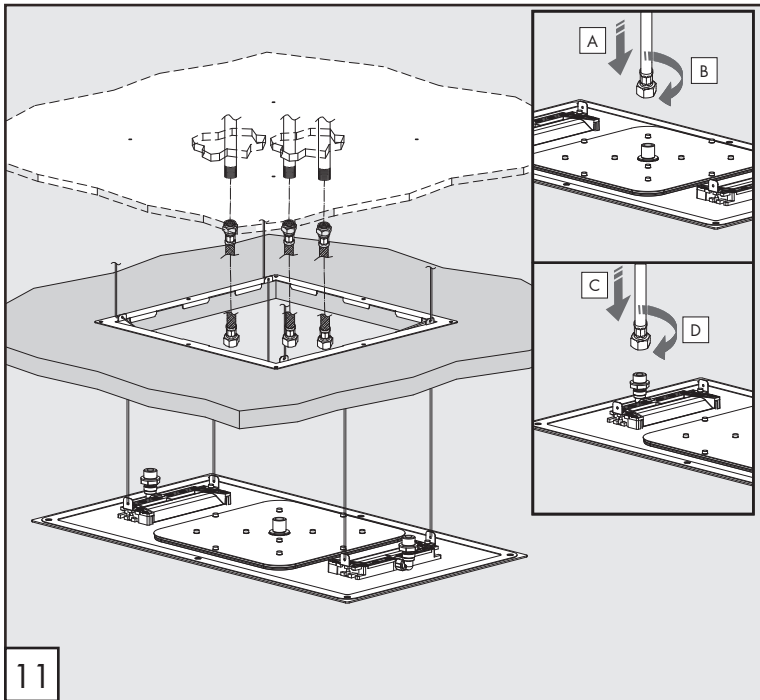
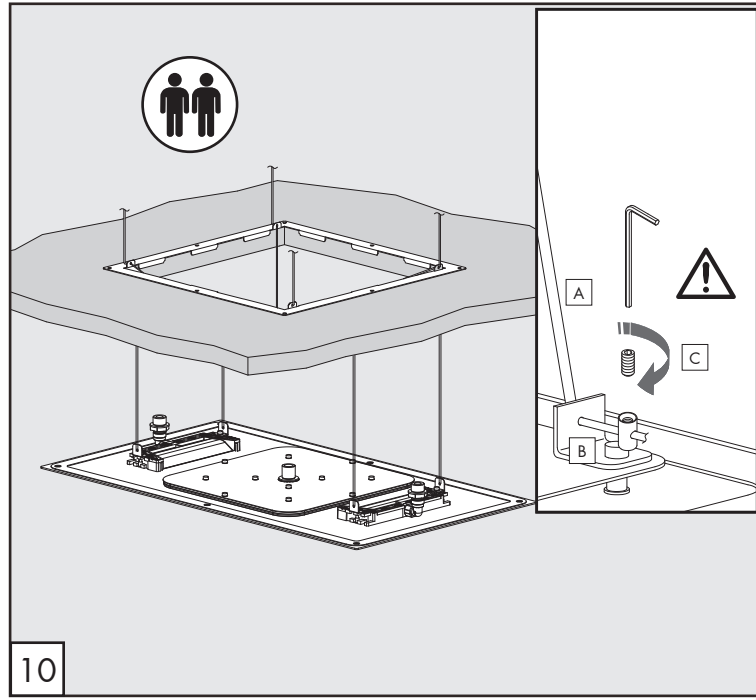
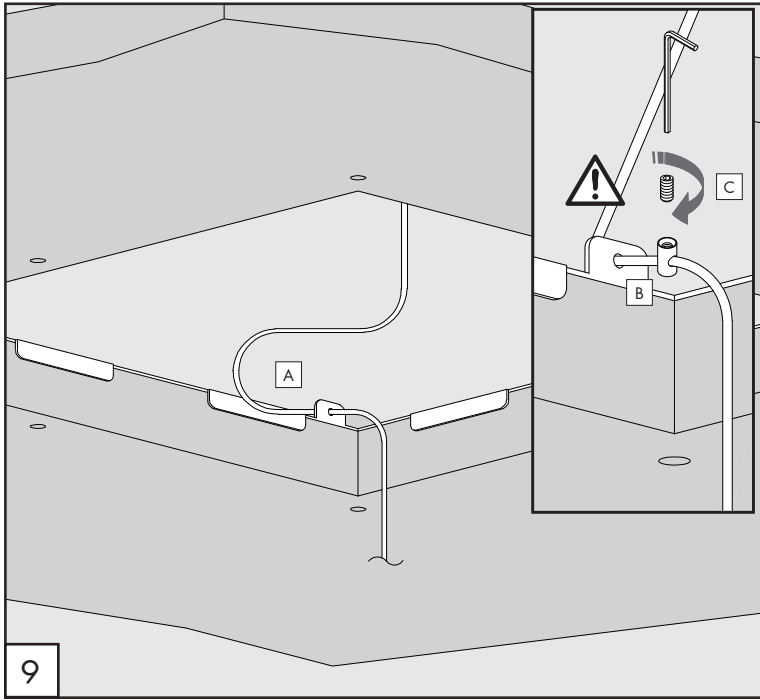



Settimanalmente pulire gli ugelli anticalcare
Weekly clean the nozzles to remove any lime scale

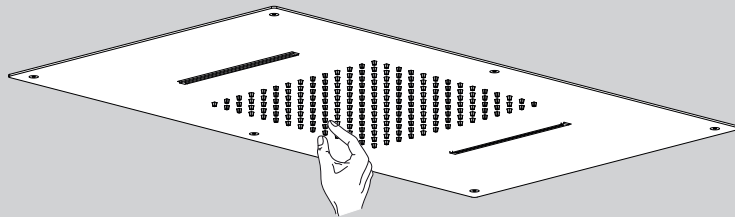

13

AQC13_REV1.1

DATI TECNICI GENERALI PER L'IMPIANTO IDRAULICO
/ TECHNICAL INFORMATION FOR THE HIDRAULIC SYSTEM

Pressione minima / *Minimum pressure*

1,5 bar

Pressione consigliata / *Recommended pressure*

2,5 - 4 bar

Pressione massima / *Maximum pressure*

5 bar

(in caso di pressioni statiche superiori a 5 bar si raccomanda l'installazione di un riduttore di pressione per evitare danni al prodotto / *Use of a pressure reducer when static pressure is higher than 5 bar to avoid damage to the product*)

 max. 65 °C
max. 149 °F

CEQ